

WIFEX



WIBEMO
OUTILLAGE DE PRÉCISION

The WIFEX family is growing...

with 2 new F16 collets

and 2 new F30 collets

Wibemo - WIFEX collets

WIFEX collet's body



PATENTED

Advantages :

WIFEX collet is an exclusive product of Wibemo especially developed to solve the gripping problems of parts by inner diameter.

This expandable collet is used as a traditional F-type collet and does not request any special sleeve or other modification.

The inner mechanism secure the opening of the collet nose in order to allow light back machining operations, facing, small holes or simply easy pick-off.



Wibemo - WIFEX collets

WIFEX collet's body - Technical Data

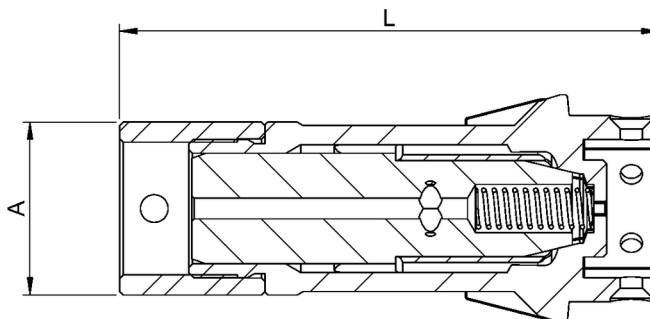

Item No	Type	EC Norm	A	L
WIFEX collet's body				
750-357	F13/357	116E	13.00	65.90
750-830	F16/830		16.00	66.00
750-1076	F16/1076	1212E	16.00	66.00
750-87	F20/87	138E	20.00	70.05
750-201	F20/201	136E	20.00	58.05
750-71	F22/71	140E	22.00	62.00
750-64	F25/64	145E	25.00	78.00
750-63	F30/63	157E	30.00	90.00
750-101	F30/101	1446E	30.00	79.00
750-94	F35/94	163E	35.00	92.90
750-740	F37/740	1536E	37.00	102.00
750-99	F42/99	171E	42.00	110.00
750-81	F48/81	173E	48.00	110.00

Wibemo - WIFEX collets

WIFEX collet jaws

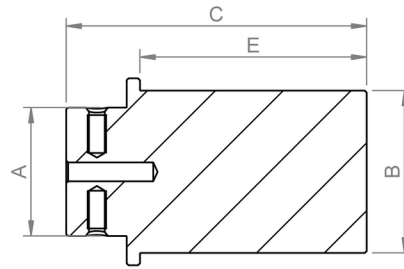

Applications :

- For any use on Wifex collets
- Various versions according to your needs
- Soft steel blank jaws for customer's finishing
- Finished version according to the part.

Hardened finished nose custom made on demand



Item No	Type	A	B	C	E
800-357	Soft nose blank F13/357	8.50	10.00	21.80	15.00
800-830	Soft nose blank F16/830	12.00	14.00	28.25	20.00
800-1076	Soft nose blank F16/1076	12.00	14.00	28.25	20.00
800-87	Soft nose blank F20/87	14.00	15.00	29.50	20.00
800-201	Soft nose blank F20/201	14.00	13.00	23.50	14.00
800-71	Soft nose blank F22/71	16.00	17.00	35.90	25.00
800-64	Soft nose blank F25/64	20.00	20.00	43.80	30.00
800-63	Soft nose blank F30/63	25.00	30.00	61.70	40.00
800-101	Soft nose blank F30/101	23.00	28.00	61.70	40.00
800-94	Soft nose blank F35/94	29.00	33.00	60.80	40.00
800-740	Soft nose blank F37/740	30.00	35.00	61.80	40.00
800-99	Soft nose blank F42/99	30.00	37.00	69.50	50.00
800-81	Soft nose blank F48/81	34.00	43.00	79.50	60.00

Wibemo - WIFEX collets

Application case 1



Clamping on a thin flange for turning a sphere and reaming

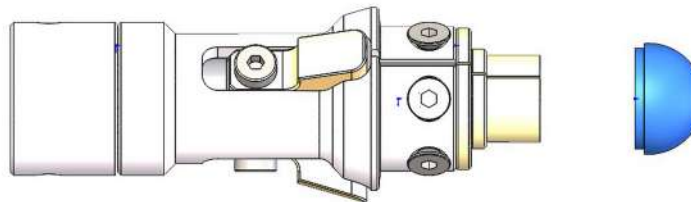
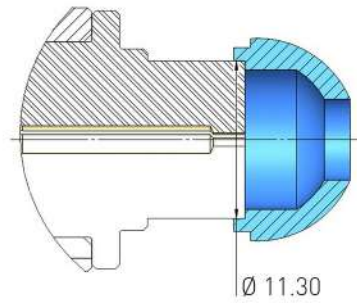

Wibemo - WIFEX collets

Application case 2



Clamping of a thin-walled part for face turning and finishing turning

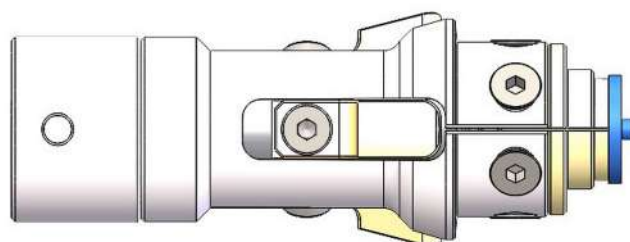
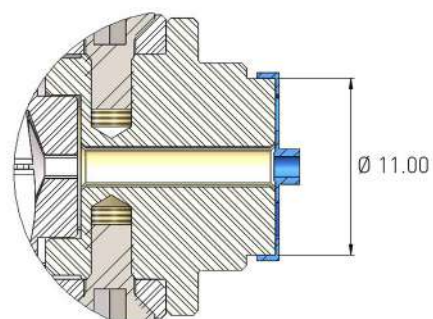

Wibemo - WIFEX collets

Application case 3



Clamping of a offset part for face turning and long finishing turning

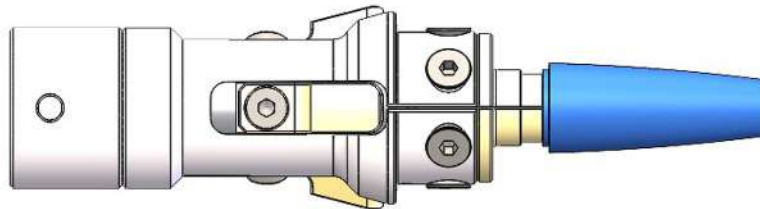
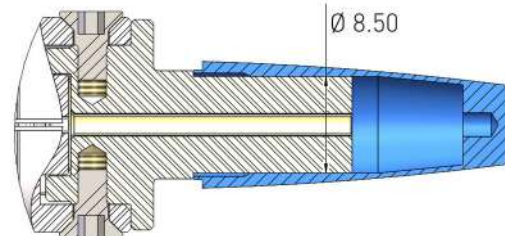

Wibemo - WIFEX collets

Application case 4



Clamping over the entire length of a part with a thin flange for face turning and reaming the internal chamfer with geometric tolerance

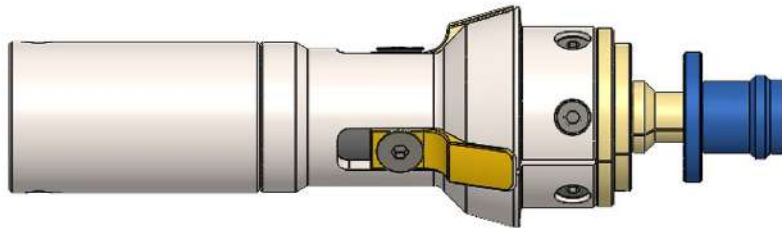
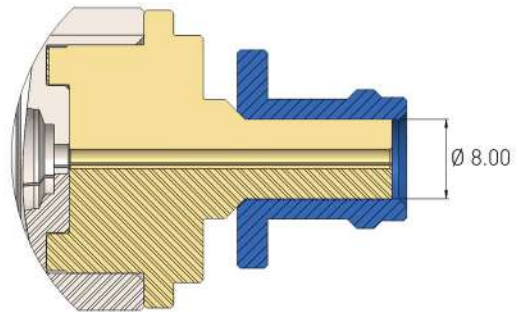

Wibemo - WIFEX collets

Application case 5



Clamping of a part with internal shapes for face turning of a large surface

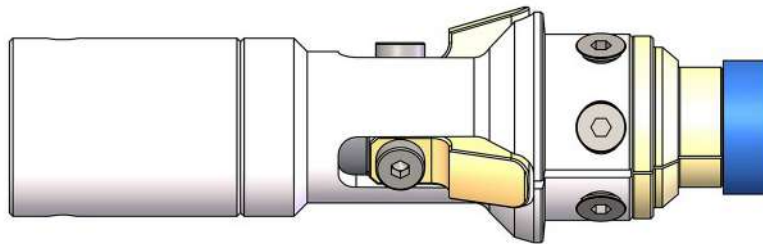
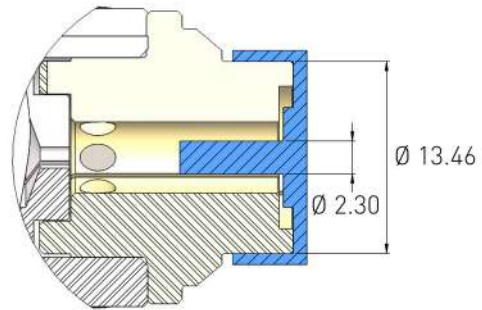

Wibemo - WIFEX collets

Application case 6



Clamping and guiding on 2 different diameters for external turning

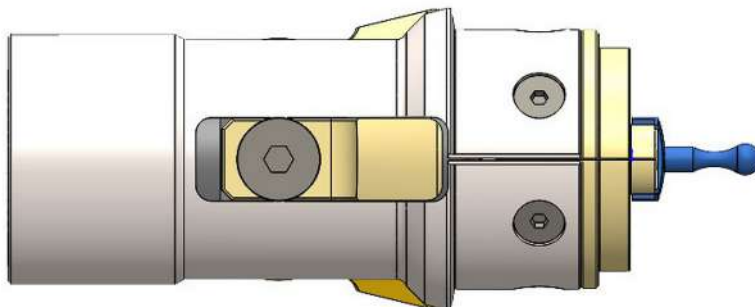
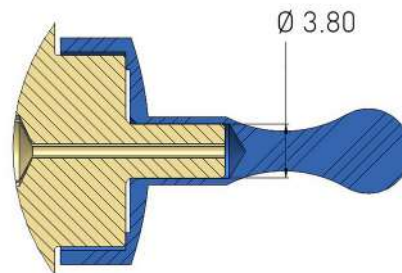

Wibemo - WIFEX collets

Application case 7



Clamping a diameter less than 0.04 inch for face turning of a few thousandths of an inch

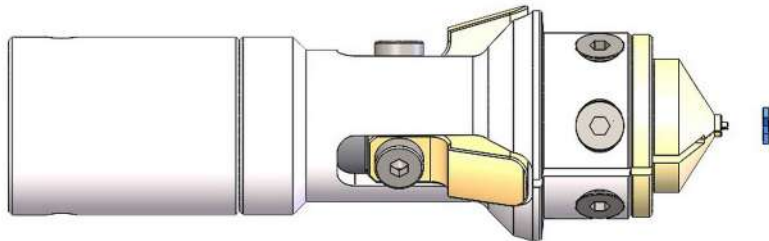
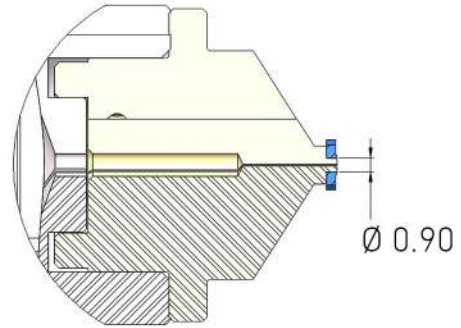

Wibemo - WIFEX collets

Application case 8



Clamping with position guide of a shaped part for non-cylindrical face turning

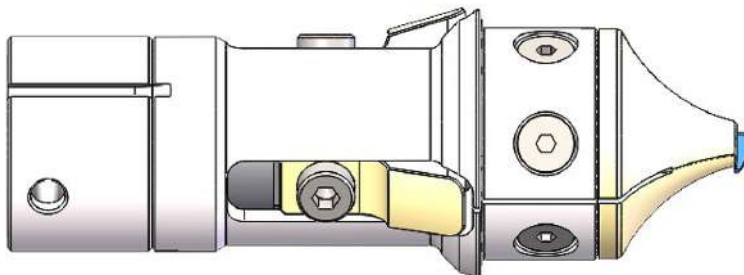
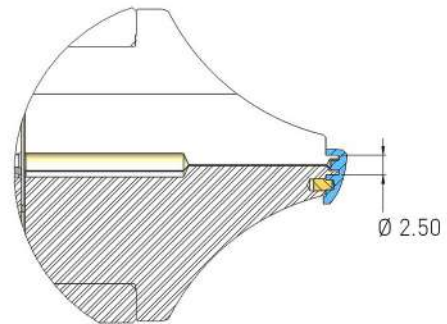

Wibemo - WIFEX collets

1 Instruction - general informations

1 General information

The WIFEX collet is specifically designed to hold work pieces in place using an internal clamping method. It is suitable for light machining operations, mainly finishing.

1.1 Recommendations

Tightening the collet when not in use puts excessive stress on the mechanism and can seriously damage it.

All our collets have an out-of-round accuracy of 0.01 mm. If you require greater accuracy, we recommend finishing the jaws directly on the machine as described in section 3.

Work as close as possible to the machine spindle. If necessary, you can cut the blank jaws down to the shortest possible length.

The work piece must be pressed firmly against the jaws to improve clamping efficiency and reduce the risk of the work piece "coming loose" during machining operations.

Carefully wash the collet nose to prevent any swarf from getting stuck in the jaws - this could prevent the mechanism from closing and cause it to jam when loading the next work piece.

After filter the oil used to wash the jaws to prevent small pieces of swarf from entering the mechanism - this can significantly reduce the collet's service life.

Ensure that the main spindle and counter-spindle rotate in perfect synchronisation.

Wibemo - WIFEX collets

2 Collet parts diagram

2 WIFEX collet parts diagram

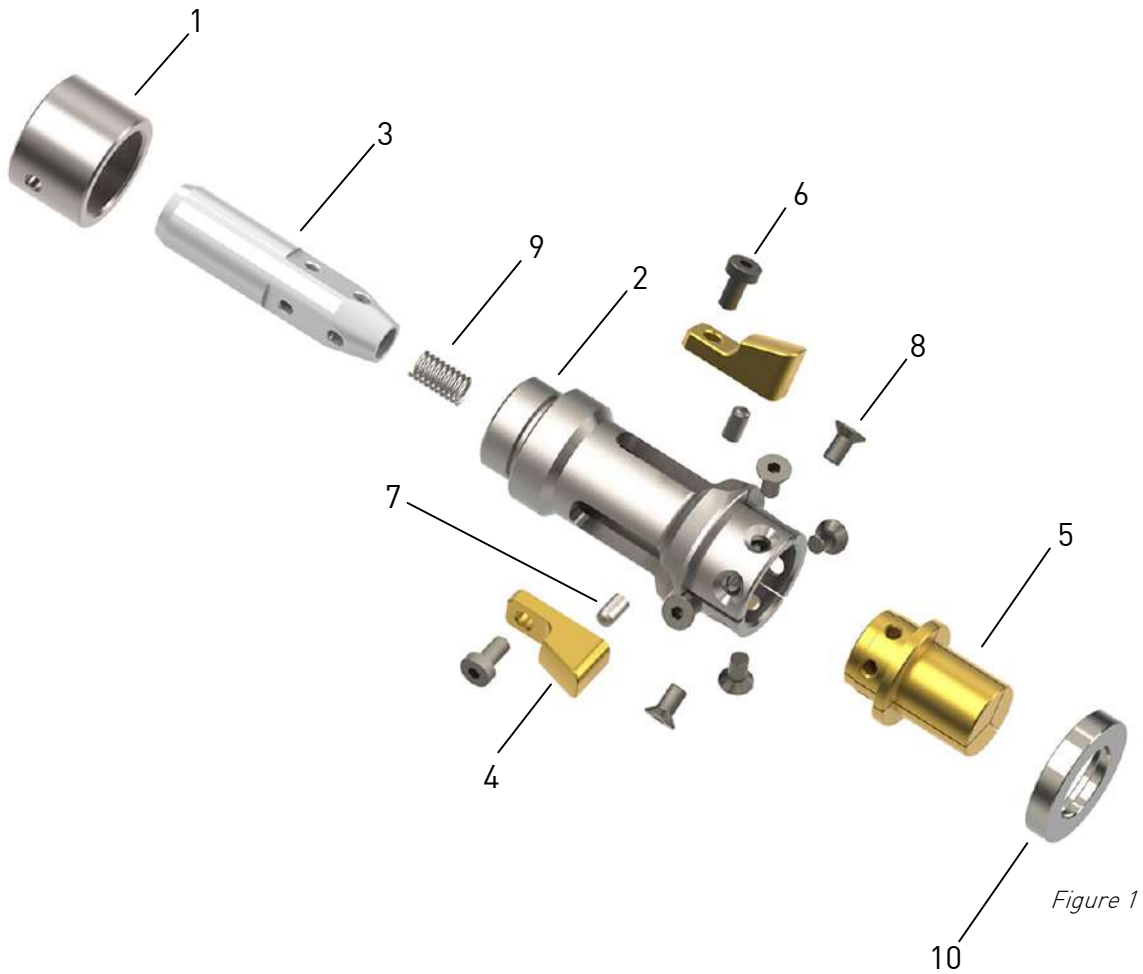

Figure 1

N°	Description	Quantity
1	Nut	1
2	Body	1
3	Push rod	1
4	Key	3
5	Interchangeable jaws	1
6	Key retaining screw	3
7	Key positioning pin	3
8	Jaw retaining screw	6
9	Spring	1
10	Limiting ring	1



Figure 2

Wibemo - WIFEX collets

3 Assembly instructions

3.1 Changing the jaws

WIBEMO supplies 3 types of jaws :

- Finished hardened jaws : requires no modification, the collet is ready to use
- Hardened blank jaws : to be finished directly on the machine
- Soft blank jaws : to be pre-machined and finished on the machine

When replacing hardened jaws, we strongly advise you to contact WIBEMO to guarantee the precision of the collet.

To replace hardened blank jaws or soft jaws, simply follow the instructions in sections 3.3 and 3.4.

When changing the jaws, it is important to **make sure that the jaws are positioned in the correct order (1-2-3)**.

WIBEMO is not responsible for any out-of-round problems with finished hardened jaws if the retaining screws (8) *(figure 1)* have been loosened.

3.2 Fitting a WIFEX collet with finished hardened jaws

A WIFEX collet with hardened jaws is ready for use. Simply fit the collet into the machine spindle.

- 1) Remove the collet previously used on the counter-spindle
- 2) Reduce the machine's clamping force (set the clamping pressure to minimum)
- 3) Clean the clamping sleeve and insert the WIFEX collet
- 4) Make sure that the manual adjustment lever is in the "open" position
- 5) Screw on the counter-spindle nose nut
- 6) Position your work piece on the WIFEX collet jaws
- 7) Adjust the machine's clamping force
- 8) The collet ready for use

3.3 Fitting a WIFEX collet with hardened blank jaws

- 1) Remove the collet previously used on the counter-spindle
- 2) Reduce the machine's clamping force (set the clamping force to minimum)
- 3) Clean the clamping sleeve and insert the WIFEX collet
- 4) Make sure that the manual adjustment lever is in the "open" position
- 5) Screw on the counter-spindle nose nut
- 6) Position the limiting ring (10) *(see figure 2)* on the collet nose
- 7) Adjust the machine's clamping force - the limiting ring fitted in step 6 will act as a stop
- 8) Machine the jaws to the correct clamping diameter. Do not add or remove any extra thickness.
Exemple : for a clamping diameter of 12.50 mm, machine the jaws to 12.50 mm
- 9) Loosen the collet
- 10) Remove the limiting ring
- 11) The collet ready for use

3 Assembly instructions

3.4 Fitting a WIFEX collet with soft jaws

- 1) Measure the useable length of the jaws from the machine flange
- 2) Dismantle the blank jaws from the body by unscrewing the 6 jaws retaining screws (8) (*see figure 1*)
- 3) Pre-cut the jaws to the desired length (*see chapter 3.5 - Pre-cutting soft jaws*)
- 4) Fit the jaws into the body ensuring that they are positioned in the correct order (1-2-3)
- 5) Remove the collet previously used on the counter-spindle
- 6) Reduce the machine's clamping force (set the clamping pressure to minimum)
- 7) Clean the clamping sleeve and insert the WIFEX collet
- 8) Make sure that the manual adjustment lever is in the "open" position
- 9) Screw on the counter-spindle nose nut
- 10) Position the limiting ring (10) (*see figure 2*) on the collet nose
- 11) Adjust the machine's clamping force - the limiting ring fitted in step 10 will act as a stop
- 12) Machine the jaws to the correct clamping diameter. Do not add or remove any extra thickness.
Exemple : for a clamping diameter of 12.50 mm, machine the jaws to 12.50 mm
- 13) Loosen the collet
- 14) Remove the limiting ring
- 15) The collet ready for use

3.5 Pre-cutting soft jaws

3.5.1 Option 1

Machine the jaws to the desired length directly on the machine - removing up to a maximum of 0.5 mm in diameter and 0.5 mm in the length.

3.5.2 Option 2

Cut the jaws to the desired length using a saw or milling machine.

Wibemo - WIFEX collets

4 Work piece ejection methods

4 Work piece ejection methods

Below you will find a table comparing the different ways of ejecting work pieces using a WIFEX collet.

Ejection fork :

Pros

- 100% control when ejecting the work piece
- No risk of damaging the work piece
- Guaranteed recovery of the work piece

Cons

- Specific location on the turret
- The tool needs to be made

Compressed air :

Pros

- Easy to set up
- Does not take up space on the turret

Cons

- Work piece ejection is not guaranteed
- There is a risk of damaging the work piece
- The work piece may fall off the swarf conveyor unit

Oil :

Pros

- Easy to set up
- Does not take up space on the turret

Cons

- Work piece ejection is not guaranteed
- There is a risk of damaging the work piece
- The work piece may fall off the swarf conveyor unit

WIBEMO only recommends using an ejection fork. It is the only method that 100% guarantees that the work piece is properly ejected, thus avoiding any risk jamming when loading the next work piece.

Wibemo - WIFEX collets

4.1 Ejection fork

4.1 Ejection fork

The fork is the perfect solution to ensure that the work piece is properly ejected. It is made up as follows :

A rod with an ejection plate which is specially designed to fit the work piece to be ejected and the type of collet is fitted in a position on the counter spindle drilling block (turret).



Figure 3



Figure 4

N°	Description	Quantity
1	Rod	1
2	Ejection plate	1
3	Screw	1

Wibemo - WIFEX collets

4.2 Using the fork

4.2 Using the fork

- 1) Position the fork in a drilling position on the counte spindle turret
- 2) Adjust the angular position of the insert so that it can be inserted behind the work piece to be ejected (*see figure 5*)
- 3) Take the references X and Z
- 4) Create code lines at the end of the machining process in order to :
 - a. position the fork behind the work piece
 - b. loosen the work piece
 - c. pull the work piece out of the jaws using the fork
 - d. move the turret to the safe position

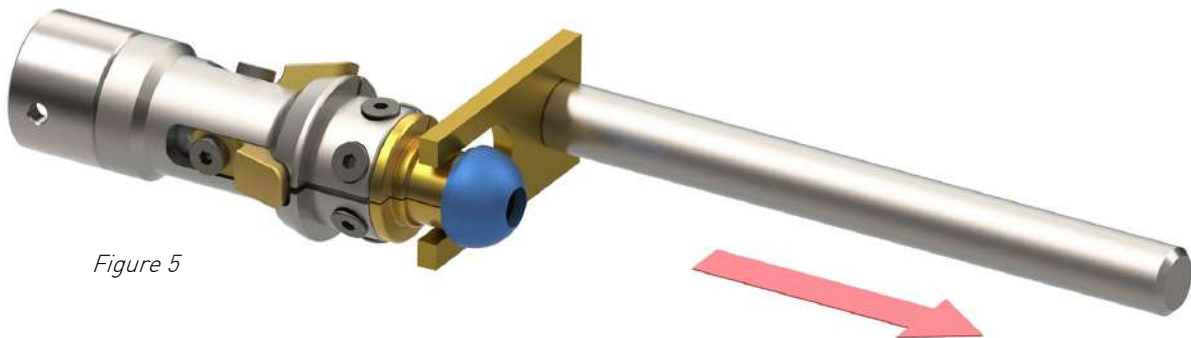

Figure 5