





NAKANISHI INC.

Headquarters · Factory
700 Shimohinata, Kanuma, Tochigi 322-8666, Japan
TEL: +81-289-64-3520 / FAX: +81-289-62-1135

www.nakanishi-inc.com
PR-K370E Ver.1 2022-02-28 03.  

※Specifications and design are subject to change without notice.

SERIES **HES**

ULTRA-HIGH-SPEED & SUPER-PRECISION

Transformer

Your machining center transforms to the high speed machining center

HES510 Max. rpm 50,000min⁻¹

HES810 Max. rpm 80,000min⁻¹

✓ Spindle accuracy within 1 μm

- Optimum for high-precision machining
- Longer tool life

✓ Ceramic Bearing

- Longer bearing life
- Higher rigidity for heavy cutting

✓ Brushless motor

- No need to replace carbon brushes to enable maintenance-free operation
- Carbon brush dust will no longer penetrate the bearing to extend the product life



[BT]



[NT]



[IT]







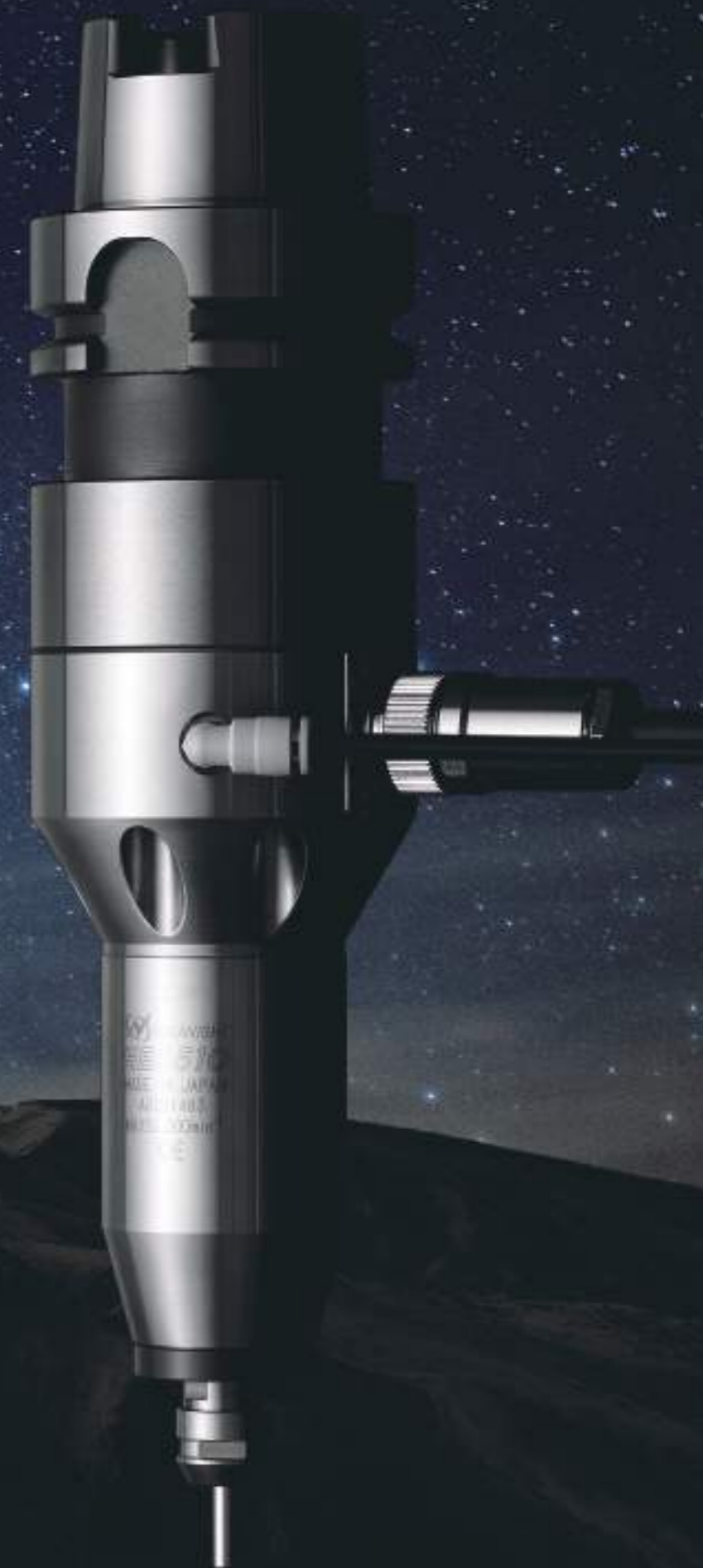

[HSK A]

A large variety of shank types are available.









Index

80,000min⁻¹ Motor Spindle

HES810-BT30 Max.rpm 80,000min ⁻¹		p.7
HES810-BT40 Max.rpm 80,000min ⁻¹		p.7
HES810-IT40 Max.rpm 80,000min ⁻¹		p.7
HES810-BT50 Max.rpm 80,000min ⁻¹		p.9
HES810-HSK A63 Max.rpm 80,000min ⁻¹		p.9
HES810-ST32 Max.rpm 80,000min ⁻¹		p.9

50,000min⁻¹ Motor Spindle

HES510-BT30 Max.rpm 50,000min ⁻¹		p.13
HES510-BT40 / NT40 (M) Max.rpm 50,000min ⁻¹		p.13
HES510-IT40 Max.rpm 50,000min ⁻¹		p.13
HES510-BT50 / NT50 Max.rpm 50,000min ⁻¹		p.15
HES510-ST32 Max.rpm 50,000min ⁻¹		p.15
HES510-HSK A63 Max.rpm 50,000min ⁻¹		p.17

Controller

E3000 CONTROLLER
Controller



p.19

Motor cord

EMCD-810-4M / 6M / 8M
Motor cord



p.20

Accessories

AL-C1204
Air line kit



p.20

CHA / CHK
Collet



p.21

CHN-A / K-265
Collet nut



p.21

Combination Example

[HES810 SERIES] HES810-BT40 + EMCD-810-4M + E3000 + AL-C1204 + CHA-4.0

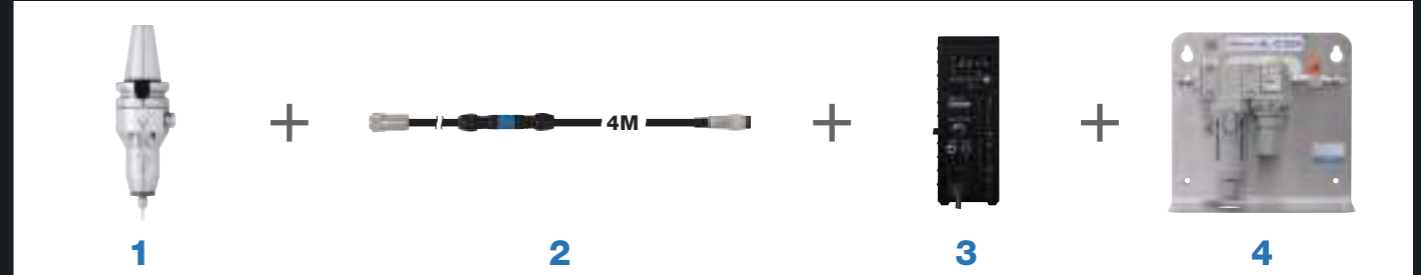

[HES810-BT40]

	Code No.	Model	Description
1	7879	HES810-BT40	Motor Spindle
2	9248	EMCD-810-4M	Motor Cord 4m
3	8421	E3000	E3000 Controller
4	4504	AL-C1204	Air line kit
5	91440	CHA-4.0	Collet ø4.0mm

[HES510 SERIES] HES510-BT40 + EMCD-810-4M + E3000 + AL-C1204 + CHK-4.0

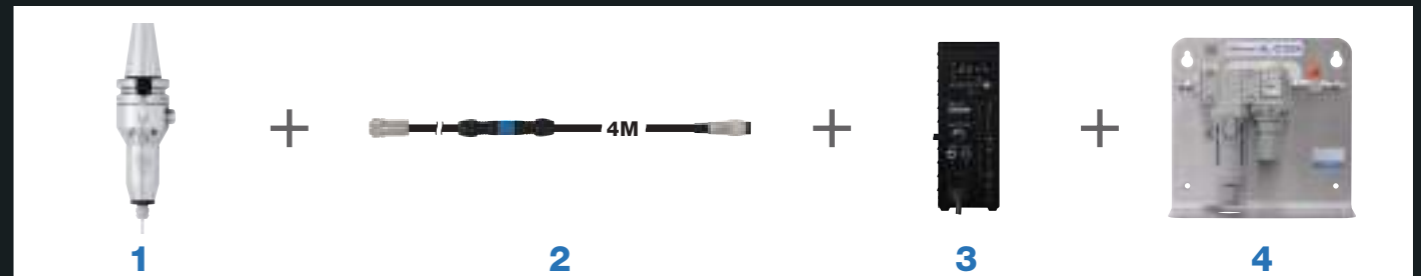

[HES510-BT40]

	Code No.	Model	Description
1	7891	HES510-BT40	Motor Spindle
2	9248	EMCD-810-4M	Motor Cord 4m
3	8421	E3000	E3000 Controller
4	4504	AL-C1204	Air line kit
5	91540	CHK-4.0	Collet ø4.0mm

Safety function

HES810 / 510 have a motor cord with the Emergency connector.
In case the machine spindle rotates by accident, the Emergency connector disconnects by itself to minimize the damage both the machine and controller.

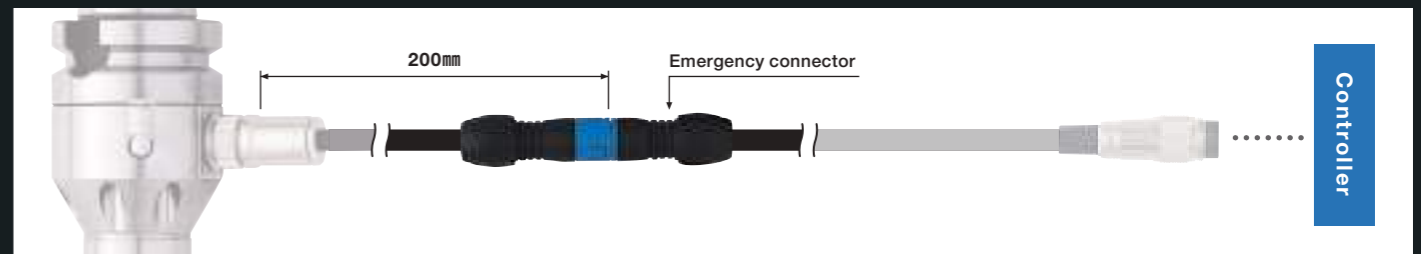

! It is crucial to install the controller and the cable according to "OPERATION MANUAL" in order to function the Emergency connector properly.

80,000min⁻¹ Motor Spindle

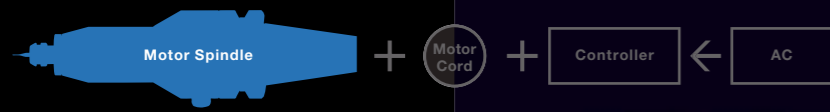

HES810-BT50

p.9

HES810-HSK A63

p.9

HES810-ST32

p.9

HES810-BT30

p.7

HES810-BT40 / IT40

p.7



80,000min⁻¹ Motor Spindle

Order by Code No.

HES810-BT30

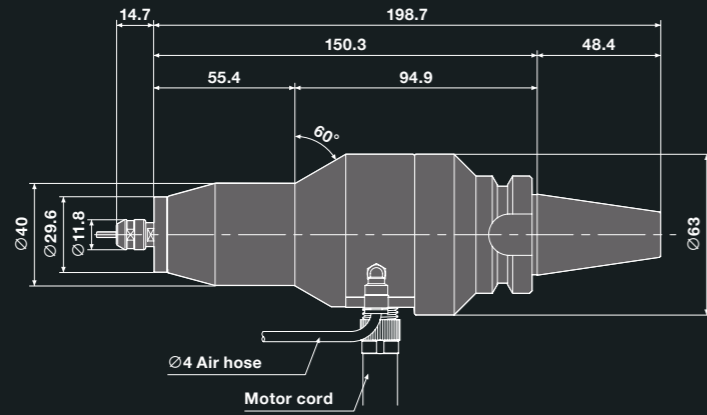

HES810-BT40

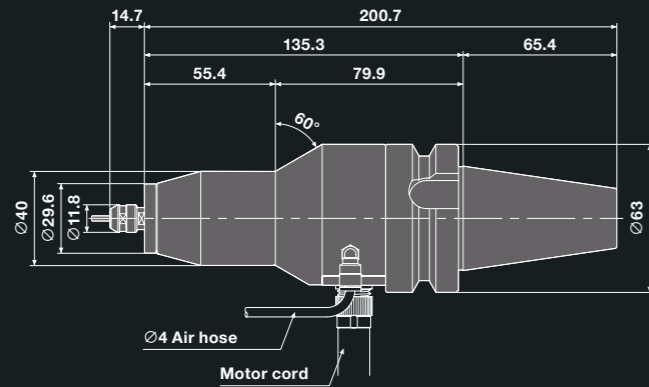

HES810-IT40

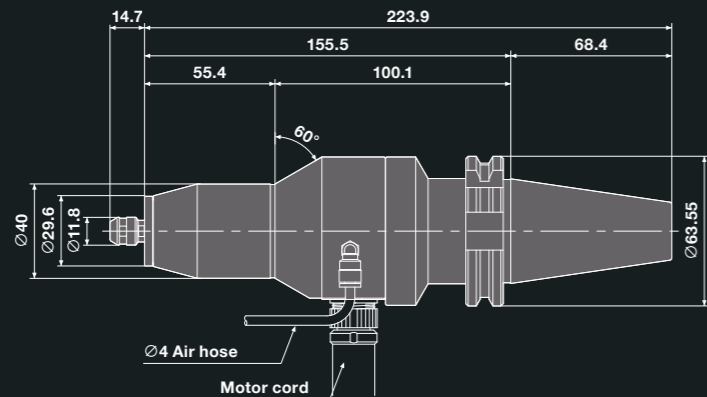

Specifications

DXF data DXF files are available on our website

HES810-BT30

Code No. **7878** Model **HES810-BT30**



Max. power	Speed Range	Spindle Accuracy	Weight
350w	20,000~80,000min⁻¹ ※Recommended motor speed : 50,000~80,000min ⁻¹	Within 1μm	2.0kg
Standard Accessories	Collet nut (CHN-A) / Wrench (8×5) · (9×11) : 1pc. each		
Options	Collet (CHA Group) : ø0.5 ~ ø4.0mm p.21 Motor cord : Length 4m (9248), 6m (9249), 8m (9250) Provided with ø4.0mm Air cooling hose		

※Collet is sold separately.

HES810-BT40

Code No. **7879** Model **HES810-BT40**



Max. power	Speed Range	Spindle Accuracy	Weight
350w	20,000~80,000min⁻¹ ※Recommended motor speed : 50,000~80,000min ⁻¹	Within 1μm	2.2kg
Standard Accessories	Collet nut (CHN-A) / Wrench (8×5) · (9×11) : 1pc. each		
Options	Collet (CHA Group) : ø0.5 ~ ø4.0mm p.21 Motor cord : Length 4m (9248), 6m (9249), 8m (9250) Provided with ø4.0mm Air cooling hose		

※Collet is sold separately.

HES810-IT40

Code No. **7883** Model **HES810-IT40**



Max. power	Speed Range	Spindle Accuracy	Weight
350w	20,000~80,000min⁻¹ ※Recommended motor speed : 50,000~80,000min ⁻¹	Within 1μm	2.4kg
Standard Accessories	Collet nut (CHN-A) / Wrench (8×5) · (9×11) : 1pc. each		
Options	Collet (CHA Group) : ø0.5 ~ ø4.0mm p.21 Motor cord : Length 4m (9248), 6m (9249), 8m (9250) Provided with ø4.0mm Air cooling hose		

※Collet is sold separately.

80,000min⁻¹ Motor Spindle

Order by Code No.

HES810-BT50

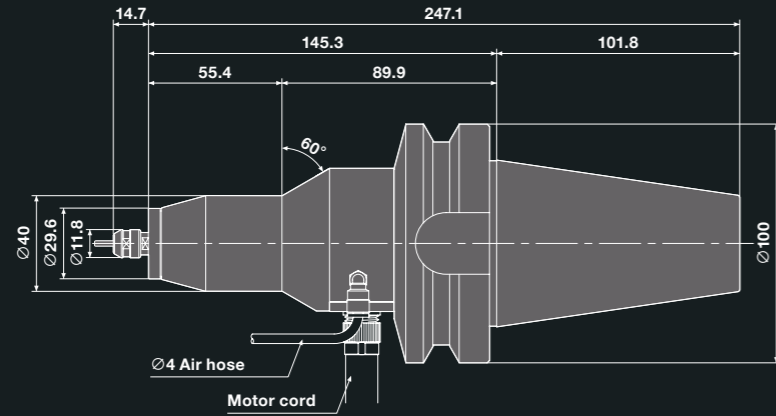

HES810-HSK A63

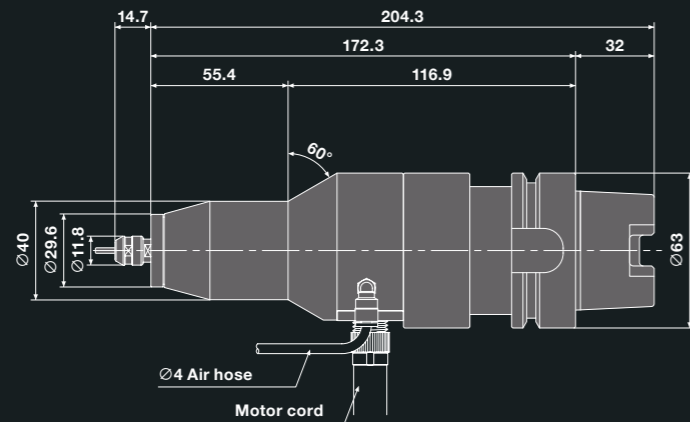

HES810-ST32

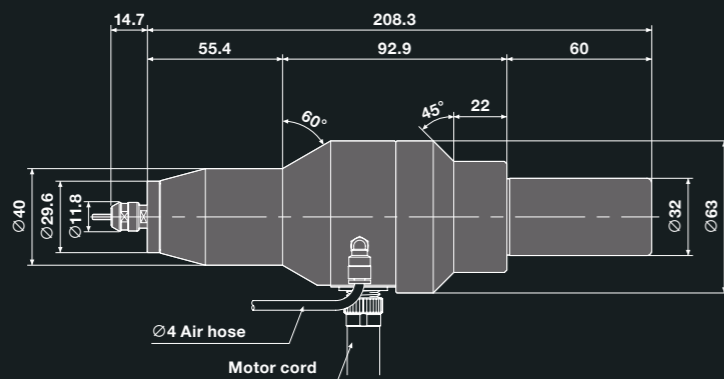

Specifications

DXF data DXF files are available on our website

HES810-BT50

Code No. **7880** Model **HES810-BT50**



Max. power	Speed Range	Spindle Accuracy	Weight
350w	20,000~80,000min⁻¹ ※Recommended motor speed : 50,000~80,000min ⁻¹	Within 1μm	4.9kg
Standard Accessories	Collet nut (CHN-A) / Wrench (8×5) · (9×11) : 1pc. each		
Options	Collet (CHA Group) : ø0.5 ~ ø4.0mm p.21 Motor cord : Length 4m (9248), 6m (9249), 8m (9250) Provided with ø4.0mm Air cooling hose		

※Collet is sold separately.

HES810-HSK A63

Code No. **7884** Model **HES810-HSK A63**



Max. power	Speed Range	Spindle Accuracy	Weight
350w	20,000~80,000min⁻¹ ※Recommended motor speed : 50,000~80,000min ⁻¹	Within 1μm	2.6kg
Standard Accessories	Collet nut (CHN-A) / Wrench (8×5) · (9×11) : 1pc. each		
Options	Collet (CHA Group) : ø0.5 ~ ø4.0mm p.21 Motor cord : Length 4m (9248), 6m (9249), 8m (9250) Provided with ø4.0mm Air cooling hose		

※Collet is sold separately.

HES810-ST32

Code No. **7885** Model **HES810-ST32**



Max. power	Speed Range	Spindle Accuracy	Weight
350w	20,000~80,000min⁻¹ ※Recommended motor speed : 50,000~80,000min ⁻¹	Within 1μm	2.3kg
Standard Accessories	Collet nut (CHN-A) / Wrench (8×5) · (9×11) : 1pc. each		
Options	Collet (CHA Group) : ø0.5 ~ ø4.0mm p.21 Motor cord : Length 4m (9248), 6m (9249), 8m (9250) Provided with ø4.0mm Air cooling hose		

※Collet is sold separately.

50,000min⁻¹ Motor Spindle

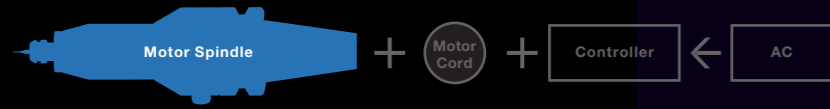

HES510-BT30

p.13

HES510-BT40 / NT40 / IT40

p.13

HES510-BT50 / NT50

p.15



HES510-ST32

p.15

HES510-HSK A63

p.17

50,000min⁻¹ Motor Spindle

Order by Code No.

HES510-BT30

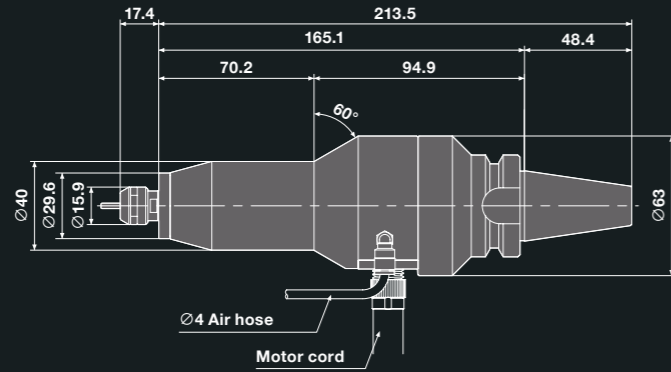

HES510-BT30

Code No. **7890** Model **HES510-BT30**



Max. power	Speed Range	Spindle Accuracy	Weight
340w	5,000~50,000min⁻¹	Within 1μm	2.2kg
Standard Accessories	Collet nut (K-265) / Wrench (12×14) : 2pcs.		
Options	Collet (CHK Group) : ø0.5 ~ ø6.35mm p.21 Motor cord : Length 4m (9248), 6m (9249), 8m (9250) Provided with ø4.0mm Air cooling hose		

※Collet is sold separately.

HES510-BT40 / NT40 (M)

[BT40]

[NT40]

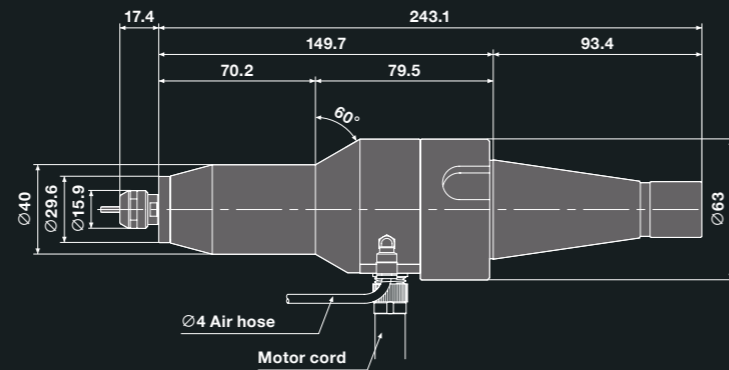
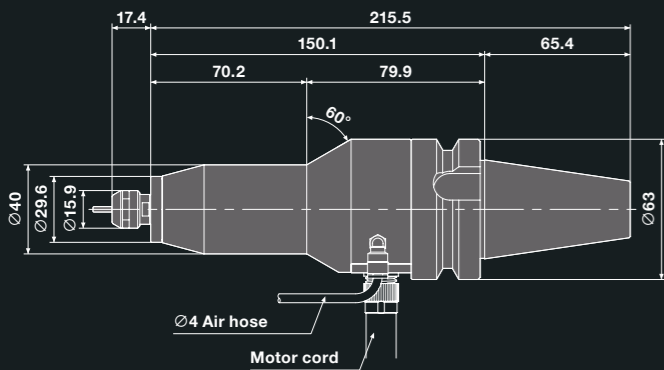

HES510-BT40 / NT40 (M)

Code No. **7891** Model **HES510-BT40**

Code No. **7887** Model **HES510-NT40**

Code No. **7888** Model **HES510-NT40M**

※NT40M-Retention knob threads are metric.
※NT40 and NT40M are discontinued products and limited in stock.

Max. power	Speed Range	Spindle Accuracy	Weight
340w	5,000~50,000min⁻¹	Within 1μm	BT40 : 2.3kg NT40(M) : 2.4kg
Standard Accessories	Collet nut (K-265) / Wrench (12×14) : 2pcs.		
Options	Collet (CHK Group) : ø0.5 ~ ø6.35mm p.21 Motor cord : Length 4m (9248), 6m (9249), 8m (9250) Provided with ø4.0mm Air cooling hose		

※Collet is sold separately.

HES510-IT40

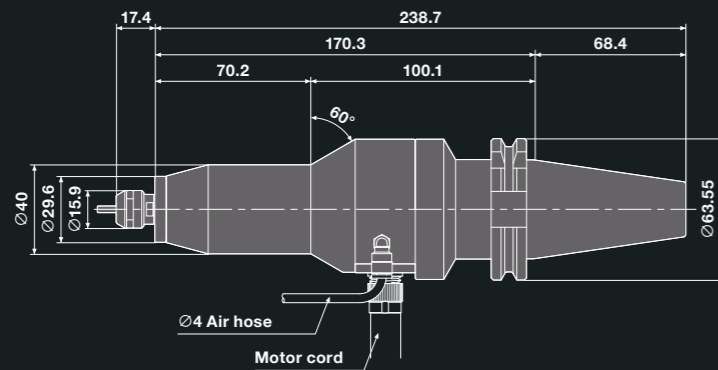

HES510-IT40

Code No. **7895** Model **HES510-IT40**



Max. power	Speed Range	Spindle Accuracy	Weight
340w	5,000~50,000min⁻¹	Within 1μm	2.6kg
Standard Accessories	Collet nut (K-265) / Wrench (12×14) : 2pcs.		
Options	Collet (CHK Group) : ø0.5 ~ ø6.35mm p.21 Motor cord : Length 4m (9248), 6m (9249), 8m (9250) Provided with ø4.0mm Air cooling hose		

※Collet is sold separately.

50,000min⁻¹ Motor Spindle

HES510-BT50 / NT50

[BT50]

[NT50]

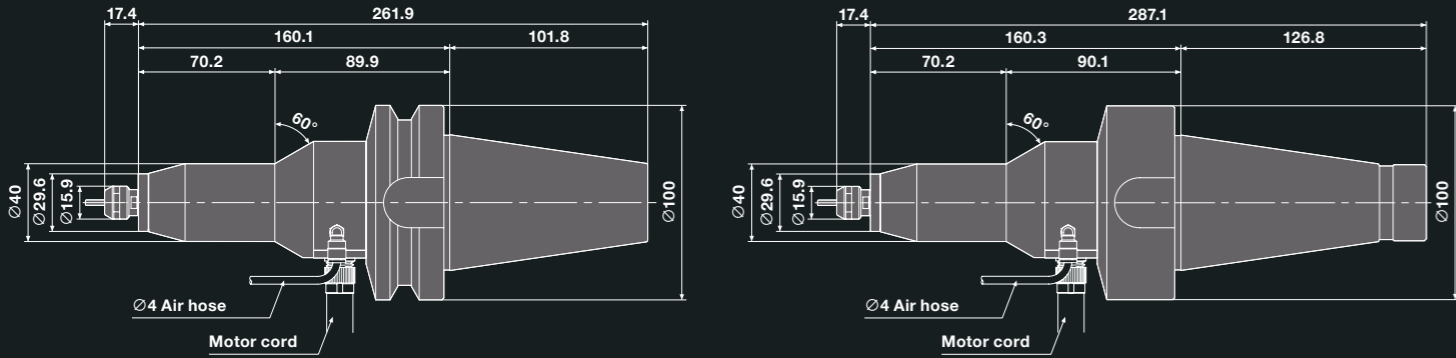

HES510-ST32

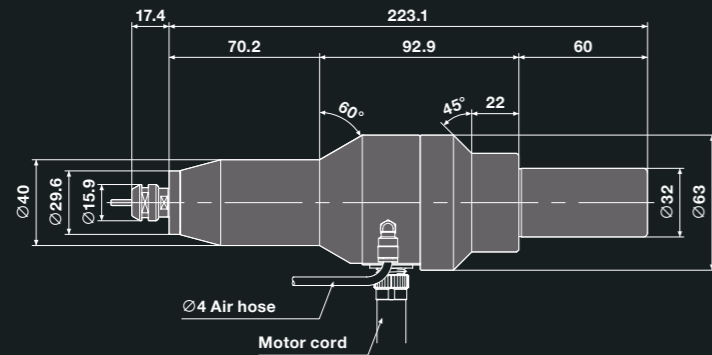

Specifications

DXF data DXF files are available on our website

Order by Code No.

HES510-BT50 / NT50



Code No.	7892	Model	HES510-BT50
Code No.	7889	Model	HES510-NT50

※NT50 is a discontinued product and limited in stock.

Max. power	Speed Range	Spindle Accuracy	Weight
340w	5,000~50,000min⁻¹	Within 1μm	BT50 : 5.0kg NT50 : 5.4kg
Standard Accessories	Collet nut (K-265) / Wrench (12×14) : 2pcs.		
Options	Collet (CHK Group) : ϕ 0.5 ~ ϕ 6.35mm p.21 Motor cord : Length 4m (9248), 6m (9249), 8m (9250) Provided with ϕ 4.0mm Air cooling hose		

※Collet is sold separately.

HES510-ST32



Code No.	7899	Model	HES510-ST32
----------	-------------	-------	--------------------

Max. power	Speed Range	Spindle Accuracy	Weight
340w	5,000~50,000min⁻¹	Within 1μm	2.4kg
Standard Accessories	Collet nut (K-265) / Wrench (12×14) : 2pcs.		
Options	Collet (CHK Group) : ϕ 0.5 ~ ϕ 6.35mm p.21 Motor cord : Length 4m (9248), 6m (9249), 8m (9250) Provided with ϕ 4.0mm Air cooling hose		

※Collet is sold separately.

50,000min⁻¹ Motor Spindle

HES510-HSK A63

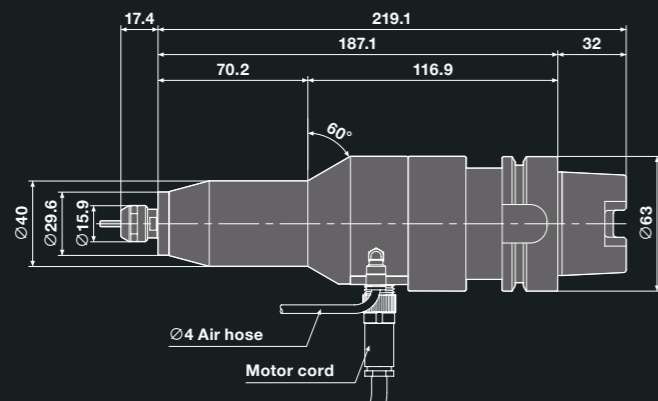

Specifications

DXF data DXF files are available on our website

Order by Code No.

HES510-HSK A63

Code No. **7897** Model **HES510-HSK A63**



Max. power	Speed Range	Spindle Accuracy	Weight
340w	5,000~50,000min⁻¹	Within 1μm	2.7kg
Standard Accessories	Collet nut (K-265) / Wrench (12×14) : 2pcs.		
Options	Collet (CHK Group) : $\varnothing 0.5 \sim \varnothing 6.35$ mm p.21 Motor cord : Length 4m (9248), 6m (9249), 8m (9250) Provided with $\varnothing 4.0$ mm Air cooling hose		

* Collet is sold separately.

E3000 Controller



E3000 CONTROLLER Controller

Code No. **8422**

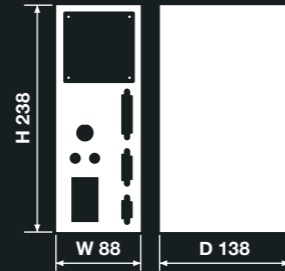

External Input / Output Control Signal Operation

- External Input
Motor ON / OFF, Error Released, Rotating Direction, Motor Speed Setting and etc.
- External Monitor
Motor Current, Error, Warning, Rotating pulse and etc.
- Parameter Setting
Maximum motor speed setting, Fix the motor speed
※For more information, please refer to the operation manual on our website.
- Equipped with safety relay break and speed point

Speed Range	
1,000~80,000min ⁻¹	
Input Voltage	
AC100~240v Without plug Multiple output power	
Max. power	Power consumption
350w	AC1.8A
Air consumption	Weight
30Nℓ/min (at 0.25~0.3MPa)	2.8kg
Standard Accessories	
Power cord : 2m / Air hose with filter (K-251 : 2058)	
Reducer / Connector cap (Included)	
Bracket / Nylon Clip / Screw / Rubber pad	
Fuse (T6.3AL) 250V : 2pcs.	

Accessories (Air line kit, Motor cord)

AL-C1204 Air line kit

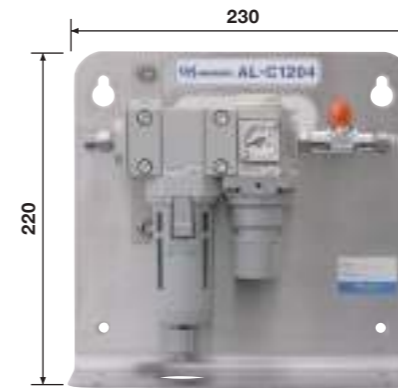

1.9kg

※Recommendation of nominal filtration rating : 0.3μm,
Pressure range : 0.1-1.0MPa Recommendation of air filter : M2000-WS (CKD)

Code No.	4504	Model	AL-C1204
Standard Accessories	Hose pipe (K-260) : 2m		

Motor cord

Motor cord	Code No.	Model	Length	Standard Accessories
4M	9248	EMCD-810-4M	4m	Air cooling hose : ø4mm Connector cap (Included)
6M	9249	EMCD-810-6M	6m	
8M	9250	EMCD-810-8M	8m	

Accessories (Collet, Collet nut)

Collet	Code No.	Model	I.D.	Compatible model		
<p>ø1.0 and over</p>	91494	CHA-3.0AA	ø3.0AA ※	HES810		
	91496	CHA-3.175AA	ø3.175AA ※			
	91495	CHA-4.0AA	ø4.0AA ※			
	91492	CHA-2.35	ø2.35			
	91430	CHA-3.0	ø3.0			
	91493	CHA-3.175	ø3.175			
<p>ø0.5~ø0.9</p> <p>Collet CHA Group</p>	91440	CHA-4.0	ø4.0	※ High precision type AA (Run-out Accuracy within 2 μm)		
	—	CHA-□□	ø0.5,ø0.6,ø0.7,ø0.8,ø0.9 ø1.1,ø1.2,ø1.3,ø1.4,ø1.7,ø1.8,ø1.9 ø2.1,ø2.2,ø2.3,ø2.4,ø2.6,ø2.7,ø2.8,ø2.9 ø3.1,ø3.2,ø3.3,ø3.4,ø3.6,ø3.7,ø3.8,ø3.9 ø1.0,ø1.5,ø2.0,ø2.5,ø3.5 ø1.6			
	<p>ø1.0 and over</p>	91597	CHK-3.0AA		ø3.0AA ※	HES510
		91598	CHK-3.175AA		ø3.175AA ※	
		91599	CHK-4.0AA		ø4.0AA ※	
		91600	CHK-6.0AA		ø6.0AA ※	
91601		CHK-6.35AA	ø6.35AA ※			
91592		CHK-2.35	ø2.35			
<p>ø0.5~ø0.9</p> <p>Collet CHK Group</p>	91530	CHK-3.0	ø3.0	※ High precision type AA (Run-out Accuracy within 2 μm)		
	91593	CHK-3.175	ø3.175			
	91540	CHK-4.0	ø4.0			
	91560	CHK-6.0	ø6.0			
	91596	CHK-6.35	ø6.35			
	—	CHK-□□	ø0.5,ø0.6,ø0.7,ø0.8,ø0.9 ø1.0,ø1.5,ø2.0,ø2.5,ø3.5,ø4.5,ø4.76,ø5.5 ø1.1,ø1.2,ø1.3,ø1.4,ø1.7,ø1.8,ø1.9 ø2.1,ø2.2,ø2.3,ø2.4,ø2.6,ø2.7,ø2.8,ø2.9 ø3.1,ø3.2,ø3.3,ø3.4,ø3.6,ø3.7,ø3.8,ø3.9 ø4.1,ø4.2,ø4.3,ø4.4,ø4.6,ø4.7,ø4.8,ø4.9 ø5.1,ø5.2,ø5.3,ø5.4,ø5.6,ø5.7,ø5.8,ø5.9 ø1.6,ø5.0			

Collet nut	Code No.	Model	Description	Compatible model
	2102	CHN-A	Collet nut for CHA collet	HES810
	2129	K-265	Collet nut for CHK collet	HES510

NAKANISHI Solutions LINE UP

Electric Motors & Spindles

Brushless Motors & Spindles



Application for CNC lathes / Special purpose machines

Application for machining centers and milling machines

E4000 SERIES

1,000~40,000min⁻¹ Max.1,200W
[ø40mm]



- World's highest power in this class
- Max. power: 1,200W, Max. torque: 1.0N·m

E3000 SERIES

1,000~80,000min⁻¹ Max.350W
[ø30/25/20mm]



- The largest product lines for various processing
- Space-saving solution for small CNC lathe

HES SERIES

Max.80,000min⁻¹
[For small diameter endmills and drills only]



- [HES810]
- The most cost effective solution to add high-speed machining capability
- 80,000min⁻¹, 6.0cN·m
- BT, HSK A63, ST shanks are available
- Driven by E3000 Controller

E2000 SERIES

1,000~50,000min⁻¹ Max.200W
[ø22.8/25mm]



- Small size spindle allows multi-axis installation in limited space

iSpeed3 SERIES

1,000~80,000min⁻¹ Max.150W
[ø19.05/20/22mm]

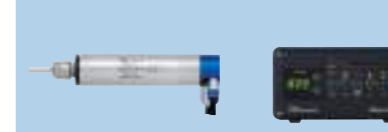

- Super short motor spindle
- High efficiency brushless motor



- [HES510]
- 50,000min⁻¹, 8.75cN·m
- BT, NT, CAT, IT, HSK A, ST shanks are available
- Driven by E3000 Controller

Air Motors & Spindles



Application for CNC lathes / Special purpose machines

Air-Speed SERIES One-piece type

Max.30,000min⁻¹ Max.130W
[ø25/23/20/19.05mm]

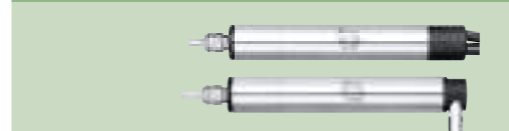

- Short body enables the spindle to mount in a limited space on a small NC/CNC lathe or on a special purpose machine

Air-Speed SERIES Modular type

Max.30,000min⁻¹ Max.130W
[ø30/25/22.8mm]



- Separate motor and spindle for flexible application changes
- Adjustable to various application through changing spindles

Air Turbine Spindles



Application for CNC lathes / Special purpose machines

Application for machining centers and milling machines

Xpeed SERIES

Max.160,000min⁻¹
[ø65/40mm]

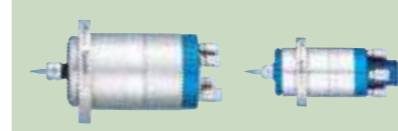

- Extreme accuracy-Runout 1μm
- For high precision small diameter drilling, internal grinding of ceramics
- Long life of spindle thanks to contactless rotation mechanism

PLANET SERIES

Max.65,000min⁻¹



- A milling machine turns into a jig grinder
- For high precision internal grinding

HTS SERIES

150,000min⁻¹
[For small diameter endmills and drills only]

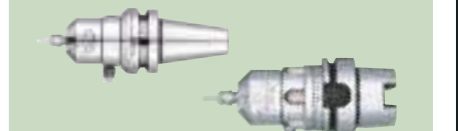

- No thermal expansion on Z axis thanks to air turbine generating little heat
- Ultra high speed 150,000min⁻¹ with higher rigidity thanks to ceramic bearings
- BT, HSK E and straight (M2040) shanks are available